

Congratulations upon your selection of this CASIO watch.

Important!

- Keep the watch's face exposed to light as much as possible (page E-4).
- This manual provides a brief overview of your watch.
- If you are going to a location where Internet access is not available, download the Operation Guide PDF from the website below to a device that you will be taking along with you.

Note that CASIO COMPUTER CO., LTD. assumes no responsibility for any damage or loss suffered by you or any third party arising through the use of your watch or its malfunction.

For details about how to use this watch and for troubleshooting information, go to the website below.

<http://world.casio.com/support/>



E-1

Important Altimeter and Compass Information!

- The Altimeter Mode displays relative altitude based on barometric pressure readings. Readings taken at different times at the same location may produce different values due to changes in pressure. The value displayed by the watch may be different from the actual elevation and/or sea level elevation of your location.
- When using the Altimeter Mode for mountain climbing or other activities, it is highly recommended that you check a map, local altitude indications, or some other source for your current correct altitude, and that you regularly calibrate the Altimeter Mode.
- When using the watch compass for serious trekking or climbing always take along another compass to confirm readings. If watch readings are different from the other compass, perform bidirectional calibration of the watch compass.
- Direction readings and calibration will not be possible if the watch is near a permanent magnet (magnetic accessory, etc.), metal objects, high-voltage wires, aerial wires, or electrical appliances (TV, computer, cellphone, etc.)
- Calibration: Operation Guide available at the CASIO website.

WAVE CEPTOR Important!

Before using the watch for the first time, use the steps below for signal reception, which sets the current time. See the Operation Guide available at the CASIO website for details.

1. Specify your Home City code (time zone where you normally use the watch).
2. Perform manual signal receive.

E-2

Contents

Charging the Watch.....	E-4
Using the Watch	E-6
Navigating Between the Timekeeping, Compass, and Altimeter Modes	E-6
Navigating to Other Modes.....	E-8
Configuring Current Time and Date Settings Automatically.....	E-10
Cities where Time Calibration Signal Reception is Supported	E-11
Auto Receive	E-11
Mode Settings.....	E-12
Changing the Current Time and Date Settings Manually	E-13
Specifications	E-14

E-3

Charging the Watch

Remove the watch from your wrist and place it in a brightly lit area.

- The watch may become hot when exposed to light for charging. Take care to avoid burn injury.
- Avoid charging in locations where it is very hot.

Power Saving

- Leaving the watch in a dark location for about one hour between the hours of 10 p.m. and 6 a.m. will cause the second hand to stop.
- Leaving the watch in a dark location for about one week will cause all hands to stop.

Battery Alerts

- Low Battery
Second hand jumps every two seconds (Low Battery Alert).
- Dead Battery
All hands stopped.

E-4

Using the Watch

Navigating Between the Timekeeping, Compass, and Altimeter Modes

- To return directly to the Timekeeping Mode from any other mode, hold down (B) for at least two seconds.
- To enter the Compass Mode or Altimeter Mode from any mode not shown in the diagram below, first return to the Timekeeping Mode.

Timekeeping Mode

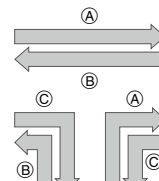

Altimeter Mode

Current altitude readings.

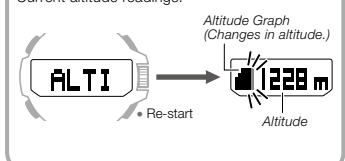

Compass Mode

Determines north and can be used to check a bearing. Point 12 o'clock at your destination, press (C).

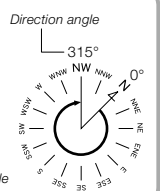
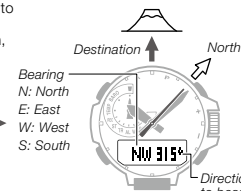
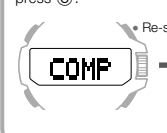

E-6

E-7

Navigating to Other Modes

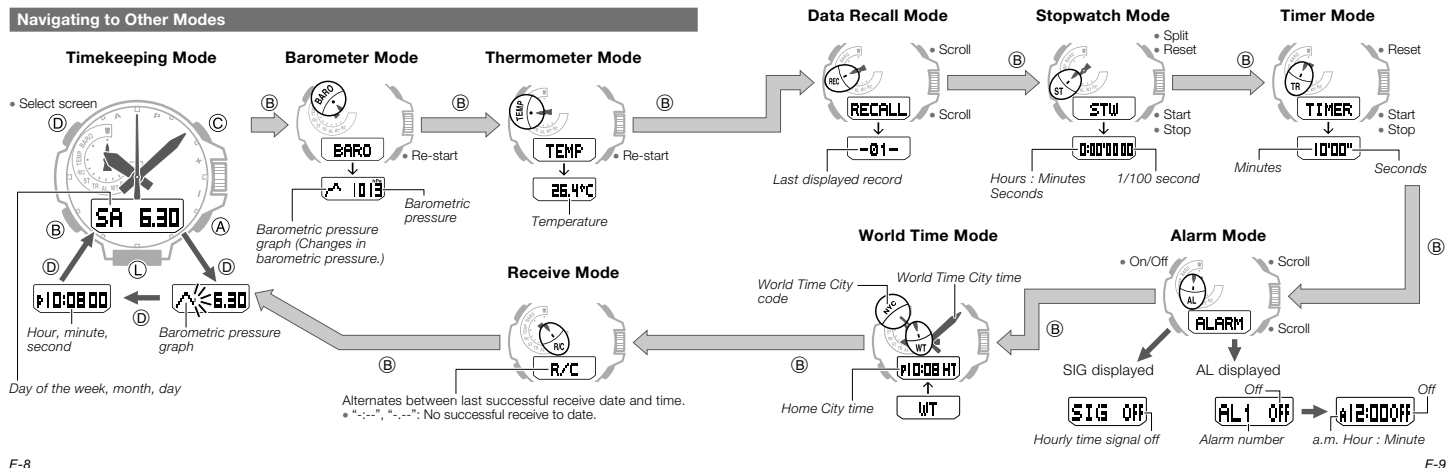

E-8

E-9

Configuring Current Time and Date Settings Automatically

- Date and time settings are kept accurate using information provided by a time calibration signal.
- Time calibration signals can be received using Auto Receive (page E-11) or Manual Receive. Normally, you should set up the watch for Auto Receive of the current time and date.
- If you are in an area where a time calibration signal cannot be received, you need to adjust time and date settings manually (page E-13).
- For information about manual receive and time calibration signal reception ranges, refer to the Operation Guide available at the CASIO website.

Important!

- For the watch to be able to receive a time calibration signal, its Home City setting must be one where time calibration signal reception is normally supported (pages E-11 and E-12).

Cities where Time Calibration Signal Reception is Supported

- TOKYO (TYO): Japan
- HONG KONG (HKG): China
- NEW YORK (NYC), CHICAGO (CHI), DENVER (DEN), LOS ANGELES (LAX), ANCHORAGE (ANC)*, HONOLULU (HNL)*: United States
- LONDON (LON), PARIS (PAR), ATHENS (ATH): United Kingdom, Germany
- * The areas covered by **ANCHORAGE (ANC)** and **HONOLULU (HNL)** are quite far from the calibration signal transmitters, so certain conditions may cause reception problems.

Auto Receive

Important!

- Perform the signal receive operation in the Timekeeping Mode. See "Using the Watch" (page E-6).
- Leave the watch near a window between midnight and 5:00 a.m.
 - When the receive operation is successful, the time and date settings will be adjusted automatically.
 - If you are unable to receive a signal, check the Operation Guide available at the CASIO website to ensure the watch is in a suitable location.

E-10

E-11

Mode Settings

- Before performing a crown operation, rotate it towards you to unlock (unscrew) it.
- You can change the following settings by operating the watch's crown: Home City, Start time (Timer), Alarm time, and World Time City.
- For full details about mode operations and calibrating measurements (direction, altitude, barometric pressure, temperature), refer to the Operation Guide available at the CASIO website.

Important!

- When not using the crown, be sure to rotate it away from you to relock it (screw it back in). This protects against damage due to impact and loss of water resistance.

E-12

Changing the Current Time and Date Settings Manually

- Timekeeping Mode: Unscrew crown. → Pull it out.
- Press (D). → Press (B) to cycle between settings.
 - Push crown back in when done.

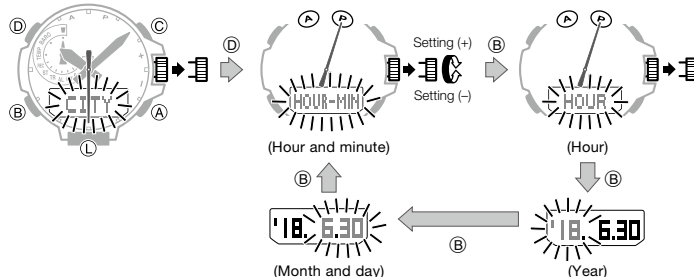

• Operation details: Operation Guide available at the CASIO website.

E-13

Specifications

Accuracy at normal temperature: ±15 seconds a month (with no signal calibration)

Digital Timekeeping: Hour, minutes, seconds, a.m. (A)/p.m. (P), month, day, day of the week, barometric pressure change indication

Time format: 12-hour and 24-hour

Calendar system: Full Auto-calendar pre-programmed from the year 2000 to 2099

Other: Three display formats (day of the week, month, day; barometric pressure change, month, day; hour, minute, second); Home City code (can be assigned one of 29 city codes); standard time/daylight saving time (summer time)

Analog Timekeeping: Hour, minutes (hand moves every 10 seconds), seconds

Time Calibration Signal Reception: Auto receive 6 times a day (5 times a day for the Chinese calibration signal); Remaining auto receives cancelled as soon as one is successful; Manual receive; Receive Mode

Receivable Time Calibration Signals: Mainflingen, Germany (Call Sign: DCF77, Frequency: 77.5 kHz); Anhorn, England (Call Sign: MSF, Frequency: 60.0 kHz); Fort Collins, Colorado, the United States (Call Sign: WWVB, Frequency: 60.0 kHz); Fukushima, Japan (Call Sign: JJY, Frequency: 40.0 kHz); Fukuoka/Saga, Japan (Call Sign: JJY, Frequency: 60.0 kHz); Shangqiu City, Henan Province, China (Call Sign: BPC, Frequency: 68.5 kHz)

Compass: 60 seconds continuous reading; 16 directions; Angle value 0° to 359°; Measurement unit: 1° (digital display)/6° (hand); North indicated by second hand; Compass calibration (bidirectional, magnetic declination angle)

Altimeter:

Measurement range: -700 to 10,000 m (or -2,300 to 32,800 ft.) without reference altitude
Display range: -3,000 to 10,000 m (or -9,840 to 32,800 ft.)

Negative values can be caused by readings produced based on a reference altitude or due to atmospheric conditions.

Measurement Unit: 1 m (or 5 ft.)

Current Altitude Data: Every second for the first 3 minutes, followed by every 5 seconds for approximately 1 hour (0'05); every second for the first 3 minutes, followed by every 2 minutes for approximately 12 hours (2'00)

Altitude Memory Data:

Manually saved records: 30 (altitude, date, time)

Auto saved values: One set of high altitude and its reading date and time, low altitude and its reading date and time, total ascent and its save start date and time, total descent and its save start date and time

Other: Reference altitude setting; Altitude differential (-100 to +100m/-1,000 to +1,000m); Altitude auto measurement interval (0'05 or 2'00)

Barometer:

Measurement and display range: 260 to 1,100 hPa (or 7.65 to 32.45 inHg)

Display unit: 1 hPa (or 0.05 inHg)

Other: Calibration; Barometric pressure graph; Barometric pressure differential pointer; Barometric pressure change indicator

Thermometer:

Measurement and display range: -10.0 to 60.0°C (or 14.0 to 140.0°F)

Display unit: 0.1°C (or 0.2°F)

Other: Calibration

E-14

E-15

Bearing Sensor Precision:

Direction: Within $\pm 10^\circ$
 Values are guaranteed for a temperature range of 10°C to 40°C (50°F to 104°F).
 North indicated by second hand: Within ± 2 segments

Pressure Sensor Precision:

Measurement accuracy: Within $\pm 3\text{hPa}$ (0.1 inHg) (Altimeter accuracy: Within $\pm 75\text{m}$ (246 ft.))
 • Values are guaranteed for a temperature range of -10°C to 40°C (14°F to 104°F).
 • Precision is lessened by strong impact to either the watch or the sensor, and by temperature extremes.

Temperature Sensor Precision:

$\pm 2^\circ\text{C}$ ($\pm 3.6^\circ\text{F}$) in range of -10°C to 60°C (14.0°F to 140.0°F)

Stopwatch:

Measuring unit: 1/100 second
 Measuring capacity: 23:59' 59.99"
 Measuring modes: Elapsed time, split time, two finishes

Countdown Timer:

Measuring unit: 1 second
 Countdown range: 60 minutes
 Setting unit: 1 minute

Alarms: 5 Daily alarms; Hourly time signal

World Time: 29 cities (29 time zones), UTC (Coordinated Universal Time); Home City/World Time City switching; one-touch UTC zone access
 Other: Daylight Saving Time/Standard Time

Illumination: LED light (LCD), ultraviolet LED light (analog hand area); Selectable illumination duration (approximately 1.5 seconds or 3 seconds); Auto Light (Full Auto Light operates only in the dark)

Other: Battery power indicator; Power Saving; Button operation tone on/off; alarm test; auto hand position adjustment; hand shift feature (to view digital info)

Power Supply: Solar panel and one rechargeable battery

Approximate battery operating time: 6 months (from full charge to Level 4) under the following conditions:

- Illumination: 1.5 seconds/day
- Beep: 10 seconds/day
- Direction readings: 20 times/month
- Climbs: Once (approximately 1 hour of altitude readings)/month
- Barometric pressure change indicator readings: Approximately 24 hours/month
- Barometric pressure graph: Readings every 2 hours
- Time calibration receive: 4 minutes/day
- Display: 18 hours/day

Specifications are subject to change without notice.

City Code Table

City Code	City	UTC Offset/ GMT Differential
PPG	Pago Pago	-11
HNL	Honolulu	-10
ANC	Anchorage	-9
LAX	Los Angeles	-8
DEN	Denver	-7
CHI	Chicago	-6
NYC	New York	-5
YHZ	Halifax	-4
RIO	Rio De Janeiro	-3
RAI	Praia	-1
UTC		0
LON	London	
PAR	Paris	+1
ATH	Athens	+2
JED	Jeddah	+3
THR	Tehran	+3.5
DXB	Dubai	+4
KBL	Kabul	+4.5

City Code	City	UTC Offset/ GMT Differential
KHI	Karachi	+5
DEL	Delhi	+5.5
KTM	Kathmandu	+5.75
DAC	Dhaka	+6
RGN	Yangon	+6.5
BKK	Bangkok	+7
HKG	Hong Kong	+8
TYO	Tokyo	+9
ADL	Adelaide	+9.5
SYD	Sydney	+10
NOU	Noumea	+11
WLG	Wellington	+12

Note

- Based on data as of July 2017.
- If the city or area you want is not included in the above table, set the Home City to a city code that is in the same time zone as the location you want to select.
- For details about the Home City, World Time City and summer time settings, refer the Operation Guide available at the CASIO website.